

GASARC™

AN ESAB® BRAND

TECH MASTER GPM4200 SERIES

4.5 Purity Single Stage Brass Barstock Piston Manual Change Gas Control Panel

The Tech Master GPM4200 series single stage manual change control panels are designed for primary pressure gas control of non-corrosive or toxic, technical gases up to grade 4.5 purity (99.995%), on gas distribution systems where slight pressure variation is acceptable.

- **GPM4211 Series** | Single Stage Single Cylinder Piston Manual Gas Change Control Panel, FKM Seal
- **GPM4212 Series** | Single Stage Single Cylinder Piston Manual Gas Change Control Panel, EPDM Seal
- **GPM4231 Series** | Single Stage Twin Cylinder Piston Manual Gas Change Control Panel, FKM Seal
- **GPM4232 Series** | Single Stage Twin Cylinder Piston Manual Gas Change Control Panel, EPDM Seal

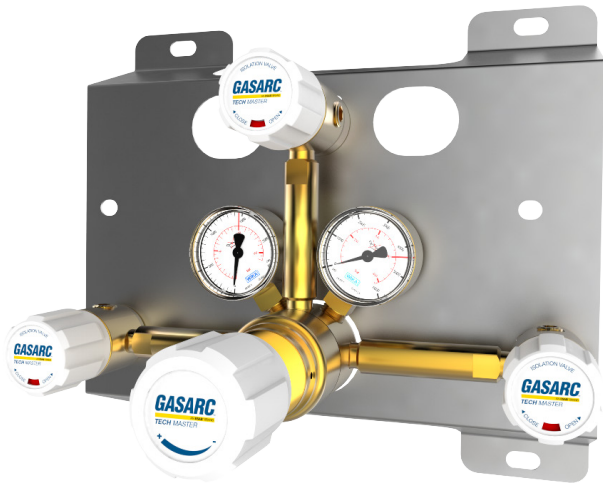

★ FEATURES

- High pressure isolation valves
- Single stage pressure regulation
- Process line isolation valve
- Encapsulated seat design
- Single and twin cylinder configuration

📄 MATERIALS

Body	Brass Barstock
Bonnet	Brass Barstock
Piston	Brass
Seal	FKM / EPDM
Seat	Polyamide (Nylon®)
Filter	10 Micron 316L Stainless Steel

👍 SPECIFICATION

Maximum Inlet Pressure	60 bar (870 PSI) / 300 bar (4350 PSI)*
Delivery Pressure Range	20 bar (300 PSI) / 50 bar (725 PSI) / 100 bar (1450 PSI) / 200 bar (2900 PSI)
Gauge	50mm (2") Diameter
Ports	¼" NPT Female
Temperature Range	-20° C to +60° C (-4° F to +140° F)
Flow Coefficient (Cv)	0.1
Weight	5.00kg (11.02 lbs)****

* Subject to cylinder connection. **** Subject to final configuration.

✓ FLOW PERFORMANCE

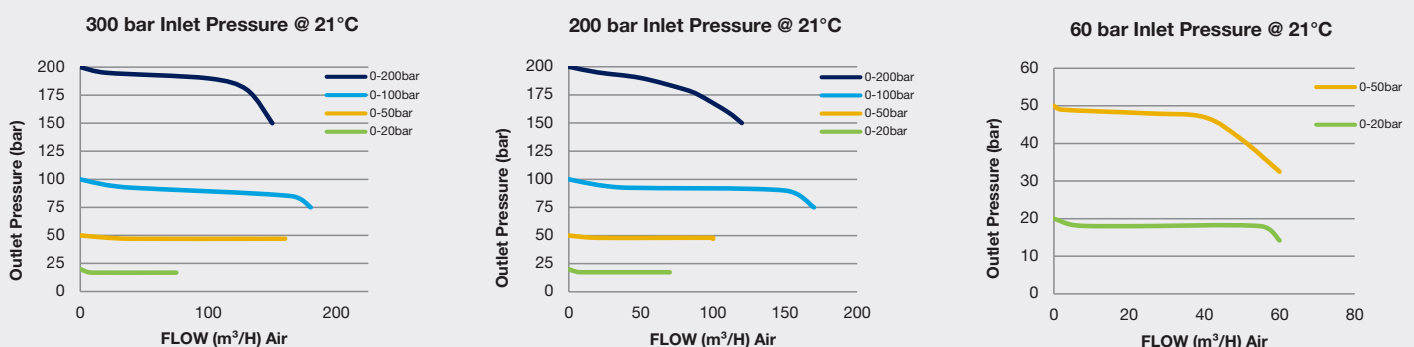

DIMENSIONS

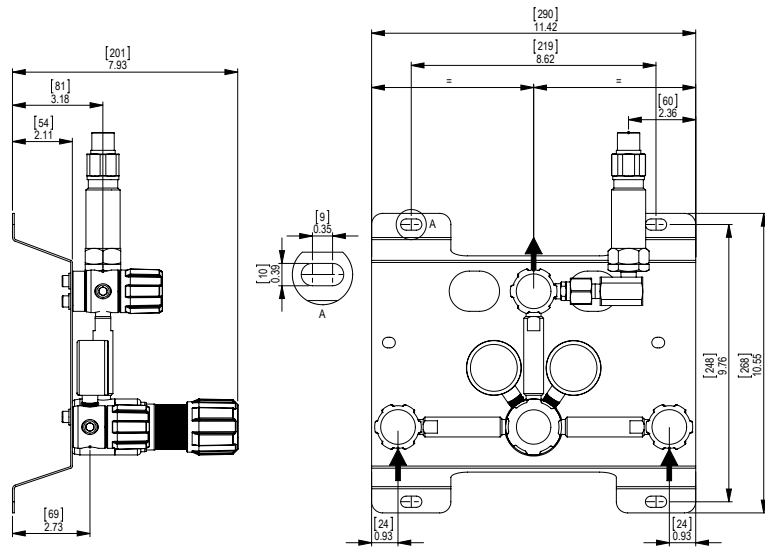

PROCESS & INSTRUMENTATION

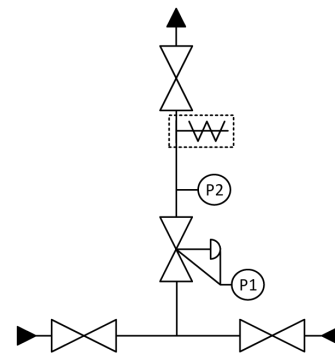

- Isolation Valve
- Adjustable Pressure Regulator with P1 Pressure Gauge
- P2 Pressure Gauge
- Pressure Relief Valve
- Denotes a Configurable Option

Model No. Selector Guide

Product Type	Inlet Pressure	Outlet Pressure	Inlet Pressure Gauge	Outlet Pressure Gauge	Inlet Connection	Outlet Connection	Options
GPM4211	02 60 bar / 870 PSI	07 -1 - 20 bar / 300 PSIG	00 No Gauge Fitted	00 No Gauge Fitted	000 No Inlet Fitted	00 No Outlet Fitted	A No Options Selected
GPM4212	04 300 bar / 4350 PSI	10 -1 - 50 bar / 725 PSIG	01 bar/PSI	01 bar/PSI	001 1/8 Stainless Steel Compression	01 1/8 Stainless Steel Compression	F Bonnet Vent Capture Kit
GPM4231		11 0-100 bar / 1450 PSI	02 bar/PSI Contact Gauge	002 1/4 Stainless Steel Compression	02 1/4 Stainless Steel Compression	K Certificate of Conformity	
GPM4232		12 0-200 bar / 2900 PSI		003 6mm Stainless Steel Compression	03 6mm Stainless Steel Compression	M CO2 Burst Disc	
					004 1/4 NPT Male	04 1/4 NPT Male	P Calibration / Pressure Test Certificate
					007 G3/8 BSP R/H Brass Male	07 G3/8 BSP R/H Brass Male	R Fitted Pipeline Pressure Relief Valve, FKM Seal
					008 G3/8 BSP L/H Brass Male	08 G3/8 BSP L/H Brass Male	S Fitted Pipeline Pressure Relief Valve, EPDM Seal
							T Fitted High Pressure Purge Facility, FKM Seal
							U Fitted High Pressure Purge Facility, EPDM Seal
							X Special Instruction