

# GASARC™

AN ESAB® BRAND

## SPEC MASTER HPM6000 SERIES

### 6.0 Purity Single Stage Nickel Plated Brass Barstock Diaphragm Manual Change Gas Control Panel

The Spec Master HPM6000 series single stage manual change control panels are designed for primary pressure gas control of non-corrosive or toxic, high purity gases up to grade 6.0 purity (99.9999%), on gas distribution systems where slight pressure variation is acceptable.

- **HPM6011 Series** | Single Stage Single Cylinder Diaphragm Manual Gas Change Control Panel, FKM Seal, FFKM Pressure Relief Valve
- **HPM6012 Series** | Single Stage Single Cylinder Diaphragm Manual Gas Change Control Panel, EPDM Seal, FFKM Pressure Relief Valve
- **HPM6031 Series** | Single Stage Twin Cylinder Diaphragm Manual Gas Change Control Panel, FKM Seal, FFKM Pressure Relief Valve
- **HPM6032 Series** | Single Stage Twin Cylinder Diaphragm Manual Gas Change Control Panel, EPDM Seal, FFKM Pressure Relief Valve



### ★ FEATURES

- High pressure isolation valves
- High pressure purge facility
- Single stage pressure regulation
- Process line isolation valve
- Encapsulated seat design
- Single and twin cylinder configuration

### 📄 MATERIALS

Body	Nickel Plated Brass Barstock
Bonnet	Nickel Plated Brass Barstock
Diaphragm	316L Stainless Steel
Seal	PTFE
Seat	PCTFE
Filter	10 Micron 316L Stainless Steel

\* Subject to cylinder connection. \*\*\*\* Subject to final configuration.

### 👍 SPECIFICATION

Maximum Inlet Pressure	60 bar (870 PSI) / 300 bar (4350 PSI)*
Delivery Pressure Range	3.5 bar (50 PSI) / 6 bar (90 PSI) / 10 bar (150 PSI)
Gauge	50mm (2") Diameter
Ports	1/4" NPT Female
Temperature Range	-20° C to +60° C (-4° F to +140° F)
Flow Coefficient (Cv)	0.1
Helium Leak Integrity	1x10 <sup>-9</sup> mbar l/s
Weight	5.0kg (11.02 lbs)****

### ✓ FLOW PERFORMANCE

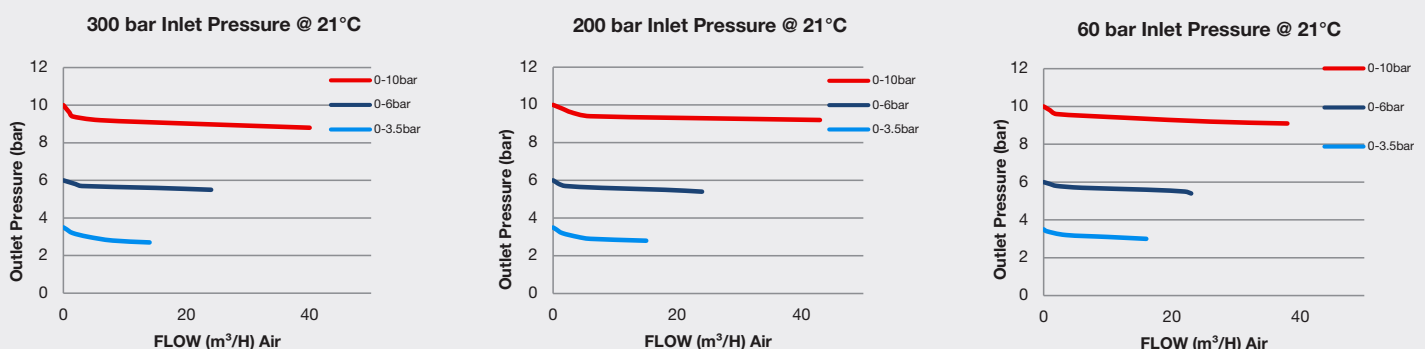

# DIMENSIONS

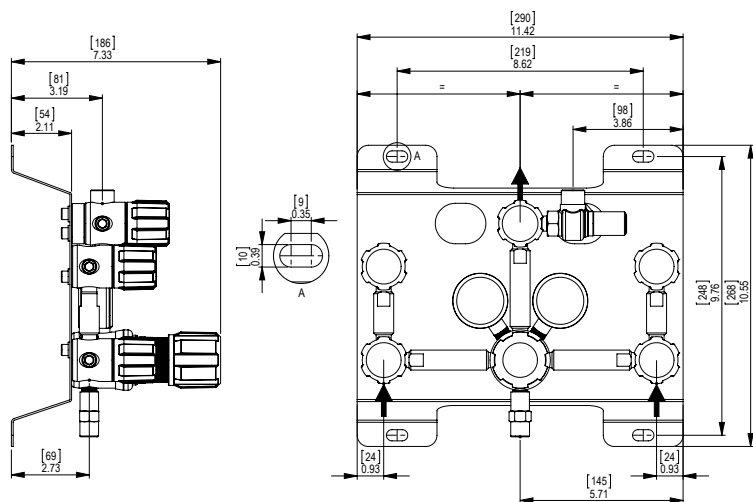

# PROCESS & INSTRUMENTATION

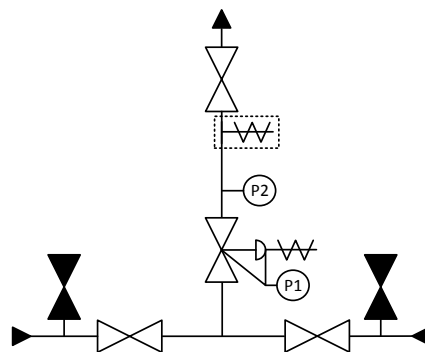

- Isolation Valve
- Isolation Valve (Closed)
- Adjustable Pressure Regulator with P1 Pressure Gauge and Pressure Relief Valve
- P2 Pressure Gauge
- Pressure Relief Valve
- Denotes a Configurable Option

## Model No. Selector Guide

Product Type	Inlet Pressure	Outlet Pressure	Inlet Pressure Gauge	Outlet Pressure Gauge	Inlet Connection	Outlet Connection	Options
HPM6011	02 60 bar / 870 PSI	03 -1 - 3.5 bar / 50 PSIG	00 No Gauge Fitted	00 No Gauge Fitted	000 No Inlet Fitted	00 No Outlet Fitted	A No Options Selected
HPM6012	04 300 bar / 4350 PSI	04 -1 - 6 bar / 90 PSIG	01 bar/PSI	01 bar/PSI	001 1/8 Stainless Steel Compression	01 1/8 Stainless Steel Compression	F Bonnet Vent Capture Kit
HPM6031		05 -1 - 10 bar / 150 PSIG	02 bar/PSI Contact Gauge		002 1/4 Stainless Steel Compression	02 1/4 Stainless Steel Compression	G Helium Test Certificate
HPM6032					003 6mm Stainless Steel Compression	03 6mm Stainless Steel Compression	K Certificate of Conformity
					004 1/4 NPT Male	04 1/4 NPT Male	M CO2 Burst Disc
					007 G3/8 BSP R/H Brass Male	07 G3/8 BSP R/H Brass Male	P Calibration / Pressure Test Certificate
					008 G3/8 BSP L/H Brass Male	08 G3/8 BSP L/H Brass Male	R Fitted Pipeline Pressure Relief Valve, FKM Seal
							S Fitted Pipeline Pressure Relief Valve, EPDM Seal
							X Special Instruction