

GASARC™

AN ESAB® BRAND

CHEM MASTER SGM6200 SERIES

6.0 Purity Single Stage Stainless Steel Piston Manual Change Gas Control Panel

The Chem Master SGM6200 series single stage manual change control panels are designed for primary pressure gas control of corrosive, toxic or high purity gases up to grade 6.0 purity (99.9999%), on gas distribution systems where slight pressure variation is acceptable.

- **SGM6211 Series** | Single Stage Single Cylinder Piston Manual Gas Change Control Panel, FKM Seal
- **SGM6212 Series** | Single Stage Single Cylinder Piston Manual Gas Change Control Panel, EPDM Seal
- **SGM6231 Series** | Single Stage Twin Cylinder Piston Manual Gas Change Control Panel, FKM Seal
- **SGM6232 Series** | Single Stage Twin Cylinder Piston Manual Gas Change Control Panel, EPDM Seal



★ FEATURES

- High pressure isolation valves
- High pressure purge facility
- Single stage pressure regulation
- Process line isolation valve
- Encapsulated seat design
- Single and twin cylinder configuration

📄 MATERIALS

Body	316L Stainless Steel
Bonnet	Nickel Plated Brass Barstock
Piston	316L Stainless Steel
Seal	FKM / EPDM
Seat	PCTFE
Filter	10 Micron 316L Stainless Steel

👍 SPECIFICATION

Maximum Inlet Pressure	60 bar (870 PSI) / 300 bar (4350 PSI)*
Delivery Pressure Range	20 bar (300 PSI) / 50 bar (725 PSI) / 100 bar (1450 PSI) / 200 bar (2900 PSI)
Gauge	50mm (2") Diameter
Ports	¼" NPT Female
Temperature Range	-20° C to +60° C (-4° F to +140° F)
Flow Coefficient (Cv)	0.1
Helium Leak Integrity	1x10 ⁻⁹ mbar l/s
Weight	5.0kg (11.02 lbs)****

** Cylinder connection not included *** Nace and 3.1 material certificates available on request, Please contact the sales office for further information. **** Subject to final configuration.

✓ FLOW PERFORMANCE

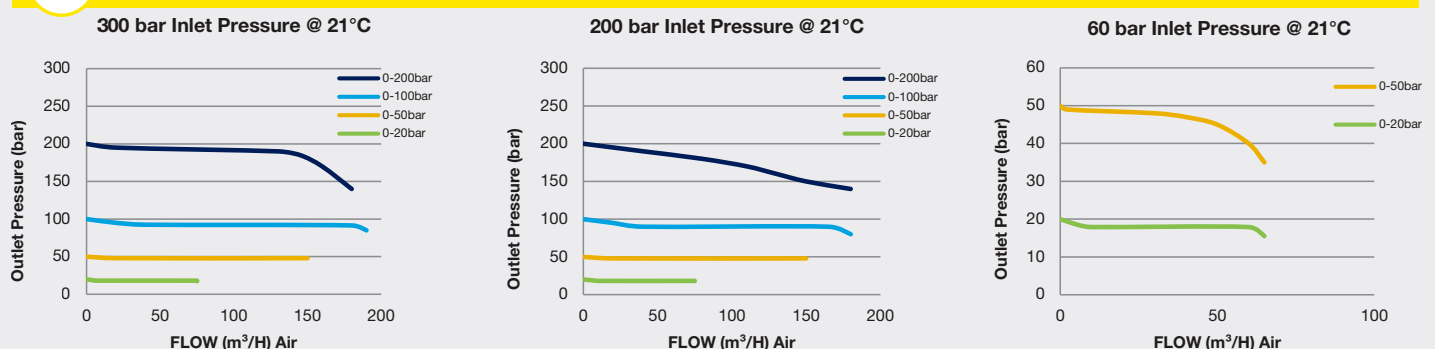

DIMENSIONS

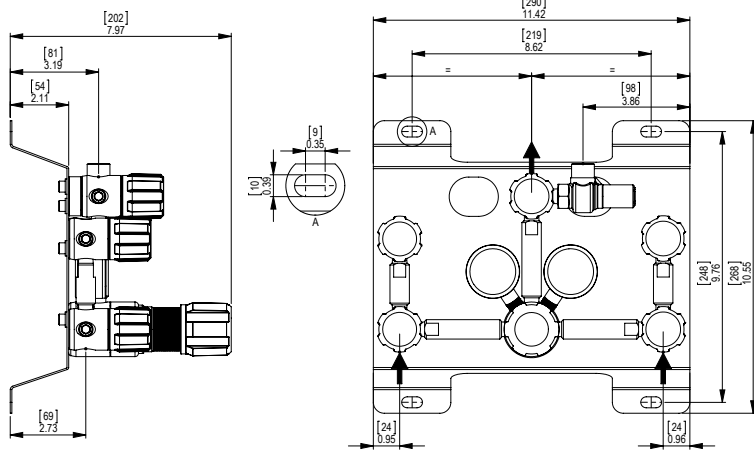

PROCESS & INSTRUMENTATION

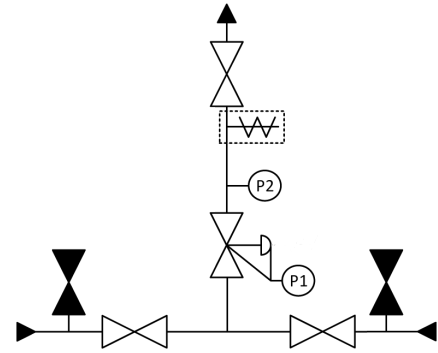

- Isolation Valve
- Isolation Valve (Closed)
- Adjustable Pressure Regulator with P1 Pressure Gauge
- P2 Pressure Gauge
- Pressure Relief Valve
- Denotes a Configurable Option

Model No. Selector Guide

Product Type	Inlet Pressure	Outlet Pressure	Inlet Pressure Gauge	Outlet Pressure Gauge	Inlet Connection	Outlet Connection	Options
SGM6211	02 60 bar / 870 PSI	07 -1 - 20 bar / 300 PSIG	00 No Gauge Fitted	00 No Gauge Fitted	000 No Inlet Fitted	00 No Outlet Fitted	A No Options Selected
SGM6212	04 300 bar / 4350 PSI	10 -1 - 50 bar / 725 PSIG	01 bar/PSI	01 bar/PSI	001 1/8 Stainless Steel Compression	01 1/8 Stainless Steel Compression	F Bonnet Vent Capture Kit
SGM6231		11 0 - 100 bar / 1450 PSI	02 bar/PSI Contact Gauge	02 bar/PSI 3.1 Cert (stainless steel only)***	002 1/4 Stainless Steel Compression	02 1/4 Stainless Steel Compression	G Helium Test Certificate
SGM6232		12 0 - 200 bar / 2900 PSI	03 bar/PSI 3.1 Cert (stainless steel only)***		003 6mm Stainless Steel Compression	03 6mm Stainless Steel Compression	H 3.1 Material Certificate***
			04 bar/PSI Contact Gauge 3.1 Cert (stainless steel only)***		004 1/4 NPT Male	04 1/4 NPT Male	J NACE Certificate***
							K Certificate of Conformity
							M CO2 Burst Disc
							P Calibration / Pressure Test Certificate
							R Fitted Pipeline Pressure Relief Valve, FKM Seal
							S Fitted Pipeline Pressure Relief Valve, EPDM Seal
							X Special Instruction